

PAS3 *regulated* ANALOG power supply upgrade

assembly and installation instructions, AN-v1, 06-2020

Introduction

This power supply replaces the original power transformer, PA211, the multi cap capacitor and any other original circuitry for the B+ and filament supply.

Power Supply

This version, ANv1, still uses the original 12X4 tube rectifier, for those who prefer to use tube rectification for their PAS2/3 preamp.

The 24VDC filament supply has been updated using a LM350 voltage regulator, which will give a fully regulated and much more stable 24VDC for the tube filaments!

Our PAS3 *regulated* power supply upgrade also uses two new transformers with much higher current capability than the original underpowered transformer.

The raw B+ from the 12X4 tube rectifier is fed through a high voltage regulator circuit and then split to individual supplies for the phono preamp and the line preamp .

In addition, the phono amp and the line amp add additional power supply filtering for each channel (left and right) directly on their individual circuit boards.

NOTE: This power supply IS NOT suitable for the original Dynaco PC6 or our clone PC6 phono preamp!

PCB Assembly

Cleanliness is essential.

IMPORTANT! Do this step FIRST!

This revised power supply can now be used with either 120VAC or 220-240VAC mains!

Before mounting ANY OTHER components, you need to install the relevant jumper links for either 120VAC or 220-240VAC operation.

For 120VAC mains operation, install jumpers J1, J2, J4 & J5 ONLY!, using the supplied wire.

For 220-240VAC mains operation, install jumpers J3 & J6 ONLY!, using the supplied wire.

To ensure that the transformers sit evenly, install these jumper links on the under side of the pcb. If you do install them on the top, you will need to 'lift' each transformer slightly as you solder them in to allow for the thickness of the jumper link.

Now, solder all the resistors and diodes in place, followed by the high voltage regulator, LR8 - U1.

Next add the power transistor, TIP50 – Q1, then the smaller capacitors, followed by the larger capacitors, and the transformers.

Mount the low voltage regulator, LM350 – U2 to the heat sink with the supplied screw & nut and install both.

The idea is to install all low profile components first, followed gradually by the higher profile components.

See the specific assembly directions below.

Be consistent in orienting the resistors; keep all the parts labels the same so they can all be read from the same side when the PCB is finished. This will pay dividends later, if you need to locate a resistor or capacitor in the wrong location.

Be sure to confirm all the electrolytic capacitor orientations, as a reversed polarized capacitor can easily vent (or even explode) when presented with high-voltage.

Confirm twice, solder once!

Make sure you use the grey thermal pad supplied with the kit when you mount the LM350 regulator to the heat sink.

If you have the heatsink which has a narrow-finned side, you MUST install the LM350 to that narrow-finned side, otherwise, it will interfere with diode D9!

Sandwich the grey insulator between the LM350 and the heatsink, see photo's below.

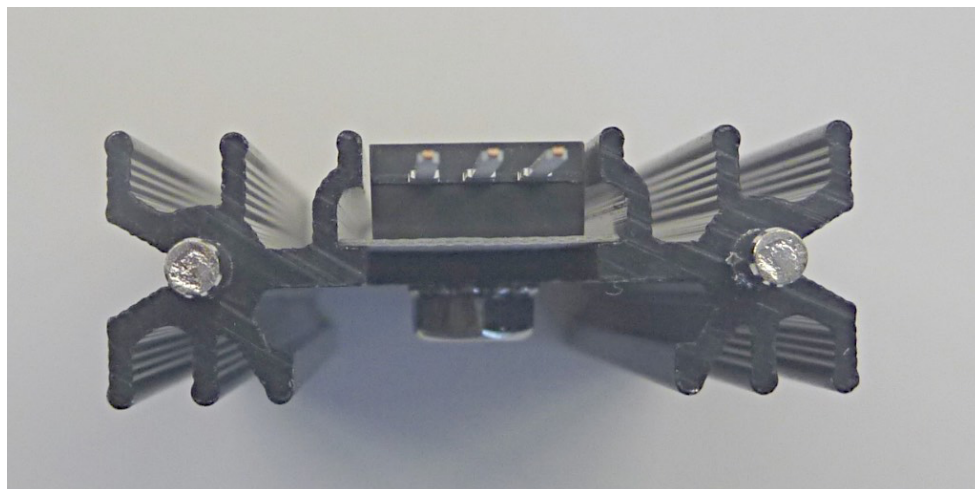
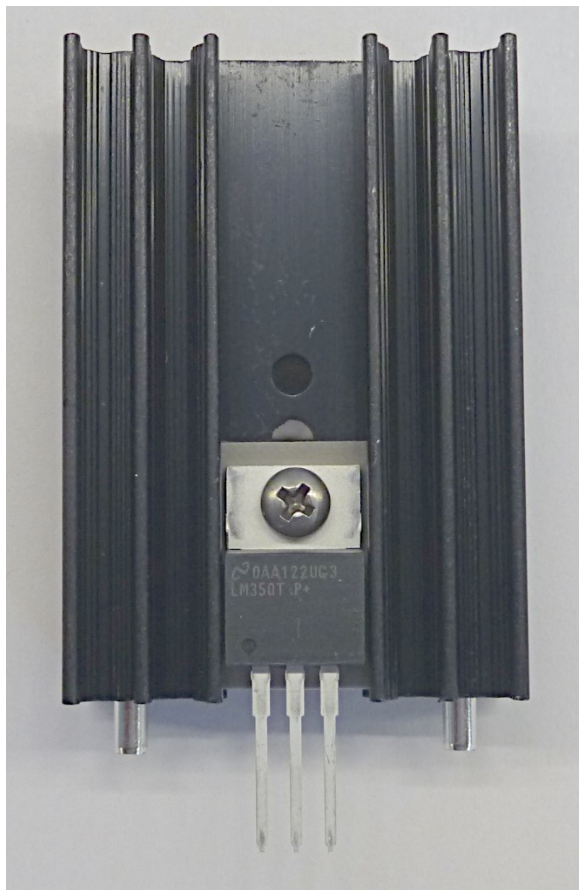

Note one side of the heatsink has narrowed fins, install the LM350 on THAT SIDE!

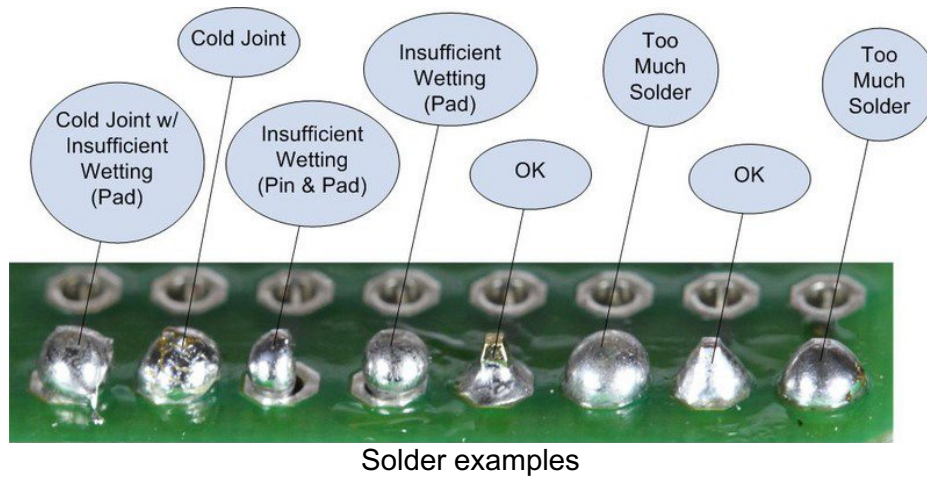

Solder examples

We cannot stress more the importance of good soldering practice. 95% of all issues with a build that we come across is bad soldering. Dry/cold solder joints are most of the issues. PLEASE ensure that your soldering skills are very good, see the above examples.

Regulated power supply PCB mounting instructions

Use this and the opposite hole to line up with existing chassis holes so that you can mark and drill the two mounting holes below

Mounting holes for this and the opposite holes need to be drilled in the chassis

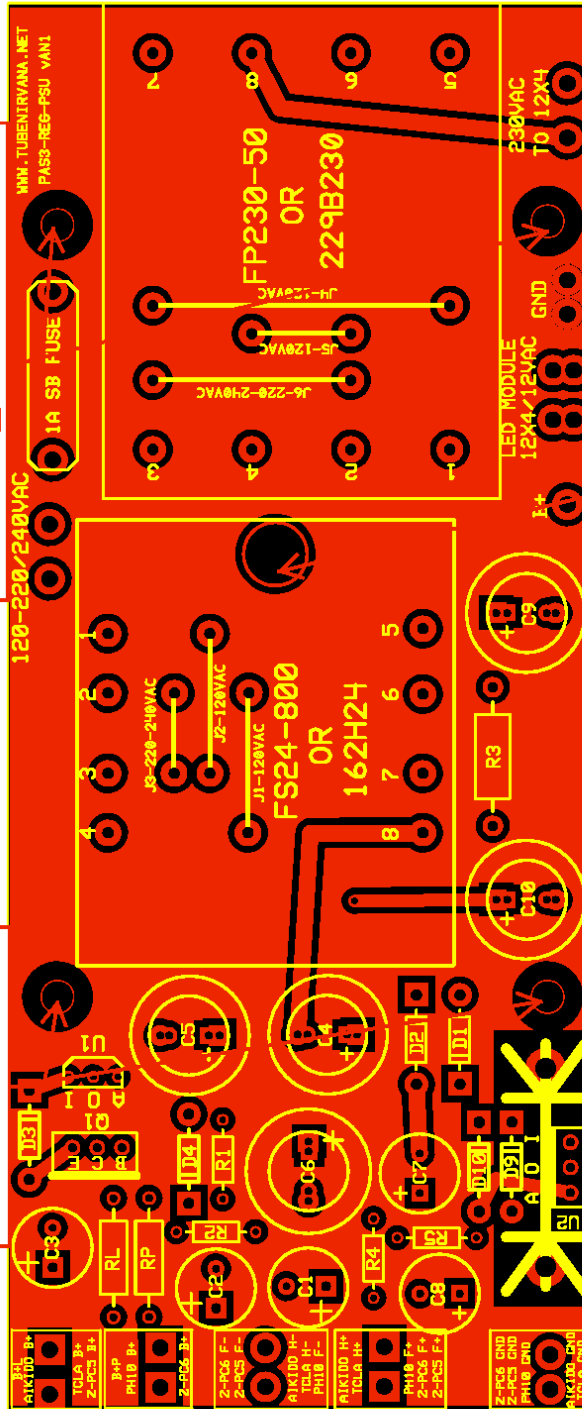

You can use this larger hole to pass wires through

As an alternative to drilling holes in your chassis, you can use the optional self adhesive pvc printed circuit board standoffs included in the kit!..

Use the supplied 4-40 washers to mount the aluminum spacers in the ORIGINAL holes, as they are quite large and the spacers could simply fall through those holes. Use one washer with a 4-40 screw and one washer under the spacer.

Do the positioning of the pcb BEFORE you populate it, ie the blank pcb!

Regulated power supply - schematic diagram

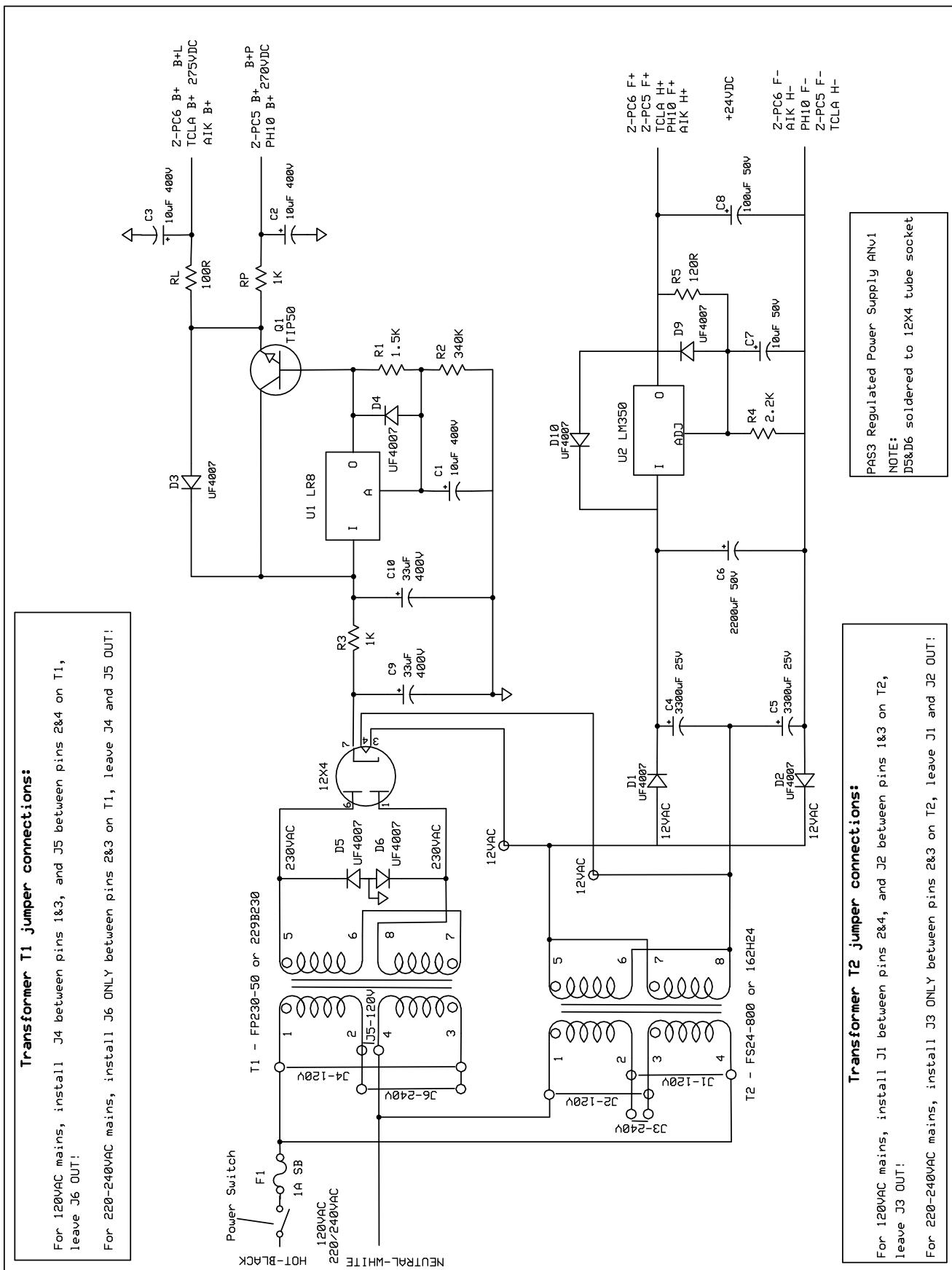

Transformer T1 jumper connections:

For 120VAC mains, install J4 between pins 1&3, and J5 between pins 2&4 on T1, leave J6 OUT!

For 220-240VAC mains, install J6 ONLY between pins 2&3 on T1, leave J4 and J5 OUT!

Transformer T2 jumper connections:

For 120VAC mains, install J1 between pins 2&4, and J2 between pins 1&3 on T2, leave J3 OUT!

For 220-240VAC mains, install J3 ONLY between pins 2&3 on T2, leave J1 and J2 OUT!

PAS3 Regulated Power Supply ANv1
 NOTE:
 D5&D6 soldered to 12X4 tube socket

NOTE: refer to the PCB layout. You will need to drill two new mounting holes. Use a 1/8" drill bit. Line up the bare PCB so that the original transformer holes line up with the two holes on the right end of the PCB, then mark and drill two holes on the other end so they line up with the other two mounting holes on the PCB>

POWER SUPPLY WIRING

- two extra diodes are supplied with the kit.

The stripe end should be soldered to pins 1 and 6 on the 12X4 tube, and the other ends to the ground lug next to the 12X4 tube – as shown on the PCB layout diagram.

After soldering all the parts onto the PCB, you'll need to add the following wires:

before installing the power supply PCB into the chassis, connect the following wires either to top or bottom side of the PCB. It is up to your preference if you wish to run the power supply wires from the top or bottom:

- a pair of twisted wires about 8" long connected to the two holes marked 120-200/240VAC. Connect the switched hot/active wire to the right pad nearest the fuse holder, the neutral wire to the remaining 120-220/240VAC pad, see below/next page for details.
- a pair of twisted wires about 8" long connected from 230VAC on the PCB to pins 1 & 6 on the 12X4 tube
- a pair of twisted wires about 8" long to holes marked 12VAC (to be connected from 12X4 tube pins 3 & 4)
- a pair of twisted wires about 8" long connected to B+ and GND on the 12X4 rectifier tube (to be connected to 12X4 pin 7 and ground lug next to 12X4 tube)
- a pair of twisted wires about 10" long connected to the relevant B+, GDN, H+/H- and F+/F- eyelets depending on the type of preamp pcb's you use.

Quoted wire lengths allow for twisting of wires, with ample reserve length.

Try and keep all AC wires away from the DC wires, use small zip ties to hold the wires neatly and securely in place.

A note about resistors:

Some 1/2W resistors look like the size of 1/4W, but they are in fact 1/2W and can generally be told apart from 1/4W as they tend to have thicker gauge leads. They are perfectly fine to be used in 1/2W placings.

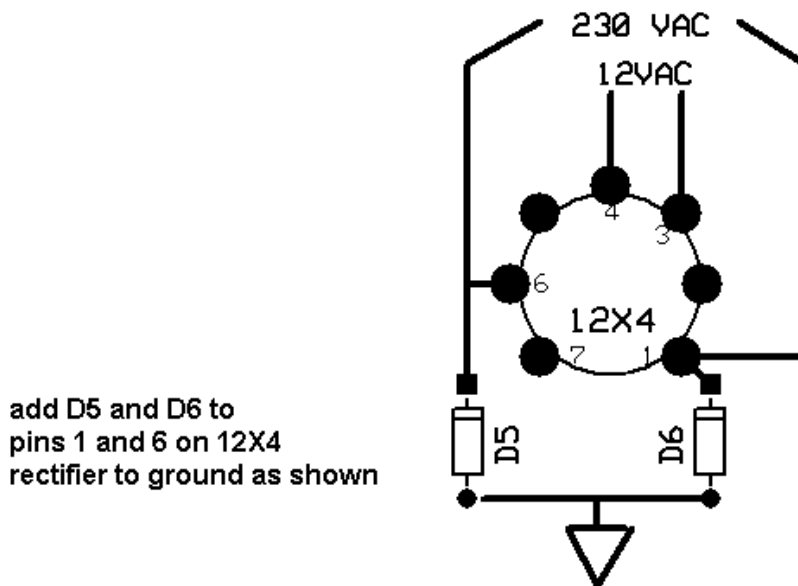

The pinout of the 12X4 above is shown looking from the TOP of the socket, NOT from the bottom!

Suggested power wiring

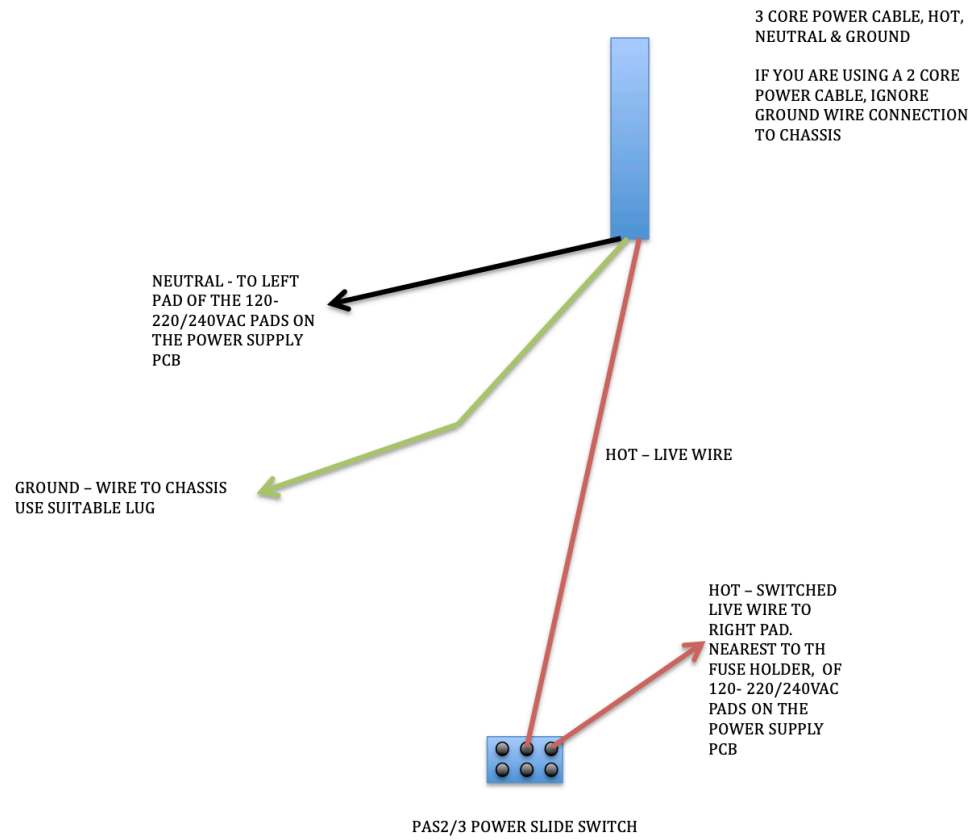

PAS3-Reg ANv1 parts list					
	Resistors	Qty		Hardware	Qty
R1	1.5K 1/4W	1		4-40x1/4" screw	9
R2	340K 1/4W	1		4-40x1/2" spacer	4
RP	1K 1/2W	1		1A SloBlo fuse	1
RL	100R 1/2W	1		Fuse holder	1
R3	1K 1W	1		TO-220 Heat Sink	1
R4	2.2K 1/4W	1			
R5	120R 1/4W	1		4-40 hex nut	1
				Jumper Wire	
	Capacitors			Thermal Pad	1
C1,2,3	10uF 400V	3			
C4,5	3300uf 25V	2			
C9&10	33uF 400V	2			
C6	2200uF 50V	1			
C8	100uF 50V	1			
C7	10uF 50V	1			
	Semiconductors				
Q1	TIP50	1			
U1	LR8	1			
D1,2,3,4	HER108/UF4007	8			
5,6,8,10					
U2	LM350	1			
	PCB				
	PAS3-REG-PSU ANv1	1			
	Transformers				
	FP230-50/229B230	1			
	FS24-800/162H24	1			

Regulated power supply PCB layout

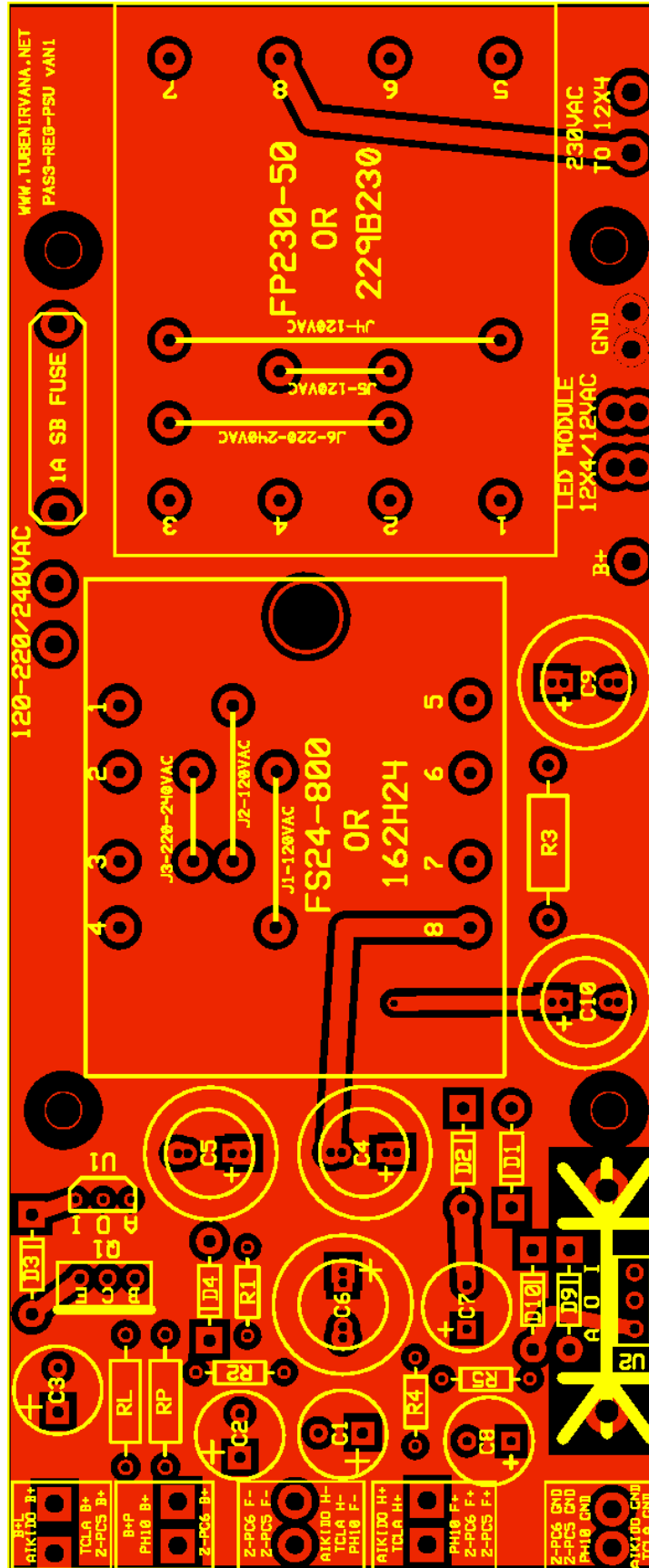

5 Band Resistor Color Coding

COLOR	1ST BAND	2ND BAND	3RD BAND	MULTIPLIER	TOLERANCE
BLACK	0	0	0	x1Ω	
BROWN	1	1	1	x10Ω	±1%
RED	2	2	2	x100Ω	±2%
ORANGE	3	3	3	x1000Ω	
YELLOW	4	4	4	x10000Ω	
GREEN	5	5	5	x100000Ω	±0.5%
BLUE	6	6	6	x1000000Ω	±0.25
VIOLET	7	7	7	x10000000Ω	±0.10
GREY	8	8	8		±0.05
WHITE	9	9	9		
GOLD					±5%
SILVER					±10%

How to read Capacitor Codes

Large capacitor have the value printed plainly on them, such as 10.μF (Ten Micro Farads) but smaller disk types along with plastic film types often have just 2 or three numbers on them?

First, most will have three numbers, but sometimes there are just two numbers. These are read as Pico-Farads. An example: 47 printed on a small disk can be assumed to be 47 Pico-Farads (or 47 pF as some like to say)

Now, what about the three numbers? It is somewhat similar to the resistor code. The first two are the 1st and 2nd significant digits and the third is a multiplier code. Most of the time the last digit tells you how many zeros to write after the first two digits, but the standard (EIA standard RS-198) has a couple of curves that you probably will never see. But just to be complete here it is in a table.

Third digit	Multiplier (this times the first two digits gives you the value in Pico-Farads)
0	1
1	10
2	100
3	1,000
4	10,000
5	100,000
6 not used	
7 not used	
8	.01
9	.1

Now for an example: A capacitor marked 104 is 10 with 4 more zeros or 100,000pF which is otherwise referred to as a .1 uF capacitor.

Most kit builders don't need to go further, but I know you want to learn more. Anyway, Just to confuse you some more there is sometimes a tolerance code given by a single letter. I don't know why there were picked in the order they are, except that it kind of follows the middle row of keys on a typewriter.

So a 103J is a 10,000 pF with +/-5% tolerance

	Tolerance of capacitor
D	+/- 0.5 pF
F	+/- 1%
G	+/- 2%
H	+/- 3%
J	+/- 5%
K	+/- 10%
M	+/- 20%
P	+100% , -0%
Z	+80% , -20%

Picofarad (pF)	Nanofarad (nF)	Microfarad (uF)	Code	Picofarad (pF)	Nanofarad (nF)	Microfarad (uF)	Code
10	0.01	0.00001	100	4700	4.7	0.0047	472
15	0.015	0.000015	150	5000	5.0	0.005	502
22	0.022	0.000022	220	5600	5.6	0.0056	562
33	0.033	0.000033	330	6800	6.8	0.0068	682
47	0.047	0.000047	470	10000	10	0.01	103
100	0.1	0.0001	101	15000	15	0.015	153
120	0.12	0.00012	121	22000	22	0.022	223
130	0.13	0.00013	131	33000	33	0.033	333
150	0.15	0.00015	151	47000	47	0.047	473
180	0.18	0.00018	181	68000	68	0.068	683
220	0.22	0.00022	221	100000	100	0.1	104
330	0.33	0.00033	331	150000	150	0.15	154
470	0.47	0.00047	471	200000	200	0.2	254
560	0.56	0.00056	561	220000	220	0.22	224
680	0.68	0.00068	681	330000	330	0.33	334
750	0.75	0.00075	751	470000	470	0.47	474
820	0.82	0.00082	821	680000	680	0.68	684
1000	1.0	0.001	102	1000000	1000	1.0	105
1500	1.5	0.0015	152	1500000	1500	1.5	155
2000	2.0	0.002	202	2000000	2000	2.0	205
2200	2.2	0.0022	222	2200000	2200	2.2	225
3300	3.3	0.0033	332	3300000	3300	3.3	335

We cannot take ANY responsibility for mains, and for that matter, ALL high voltage AC and DC wiring you carry out. We have described in this, and all of our other manuals, as best as we can, on how to wire up these high voltage connections.

You MUST take EXTREME care, that no wires are shorted together, or to the chassis, or any other part of the assembly and pcb's.

All these high voltages can be life threatening, and can hurt you or others if carried out incorrectly.

Use your meter in the continuity setting to make sure no high voltage wires are shorted together or to chassis ground.

Apart from bodily harm, incorrect high voltage wiring can and will damage components!

You are totally and solely responsible for all high voltage wiring and the general assembly of this kit!

We have wired our prototype amp exactly as described in this and all of our other manuals, so we know that the amp will work as designed and intended!

If you are unsure of how to carry out some of our instructions, PLEASE contact us via e-mail, we provide, as part of our service, full support for this and all of our kits!

No question is stupid. The ONLY stupid question is the one you do not ask!